



EUROBELT
MODULAR BELTS



Q50 FLAT TOP
NSF 14159-3

S E R I E S

Q50

F L A T T O P



**NEW MODULAR BELTS
GENERATION**

PATENTED

 **quickbelts**

PATENTED



quickbelts

DISCOVER THE NEW GENERATION OF MODULAR BELTS

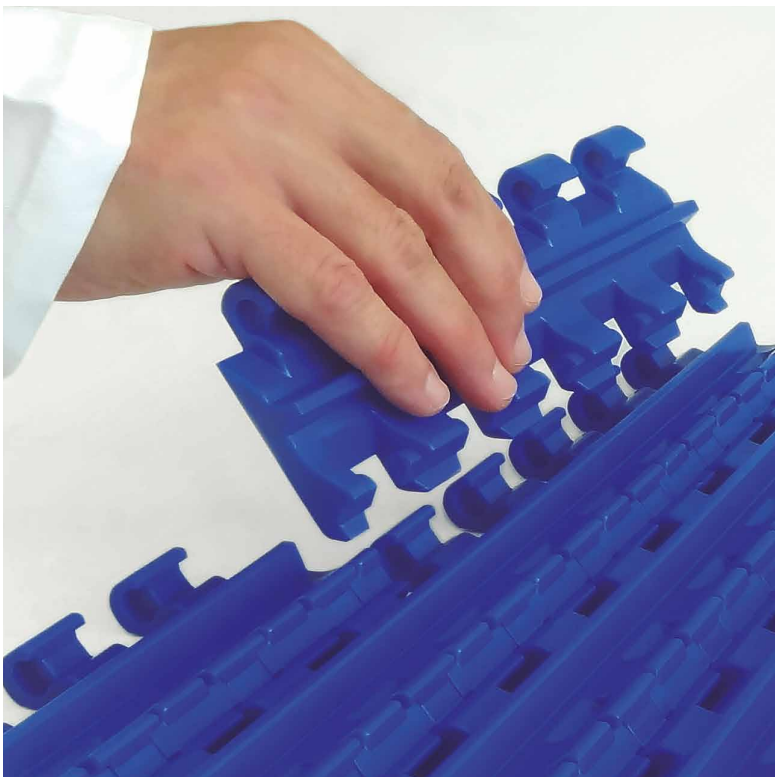

quickbelts is a new generation of belts whose assembly system does not require connecting rods.

With just **one click**, your quickbelts' parts fit together without any extra fastening, so that the assembly is much **faster and easier**.

Given its particular geometry, the belt develops a slight lifting during the transfer. This makes easier the **take off of the product**.

In addition, its structure without holes, allows an **excellent cleaning**.

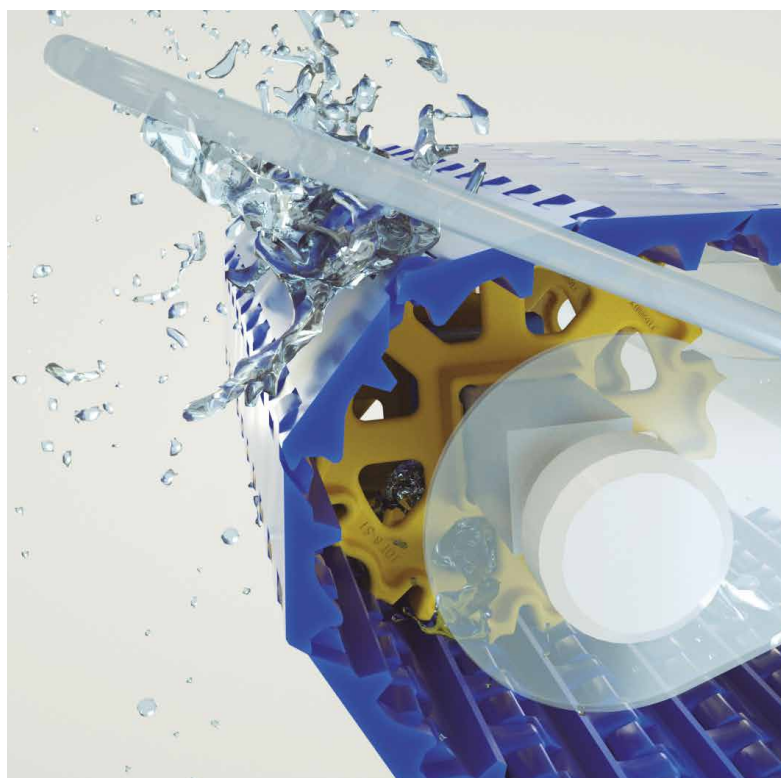
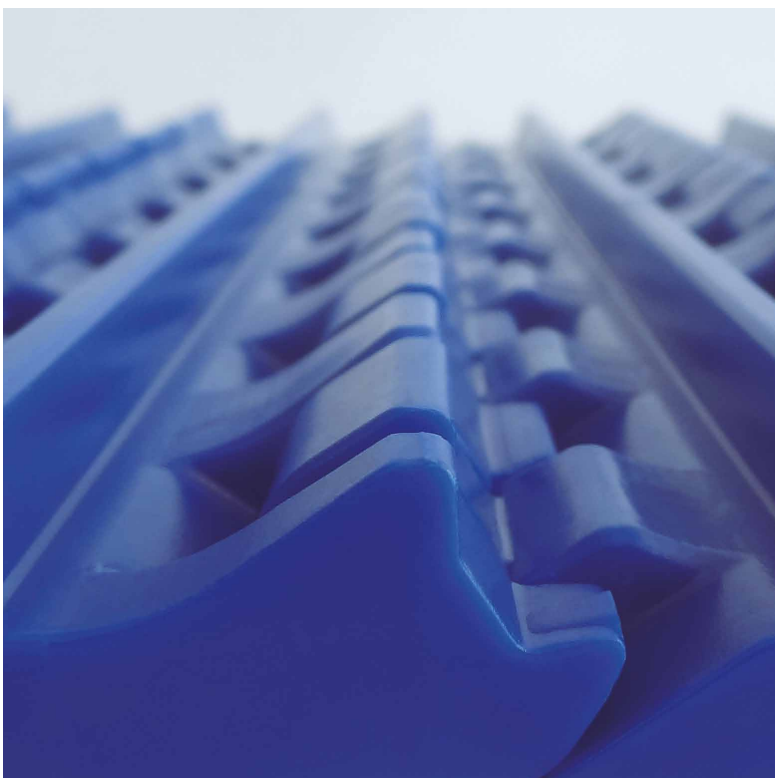

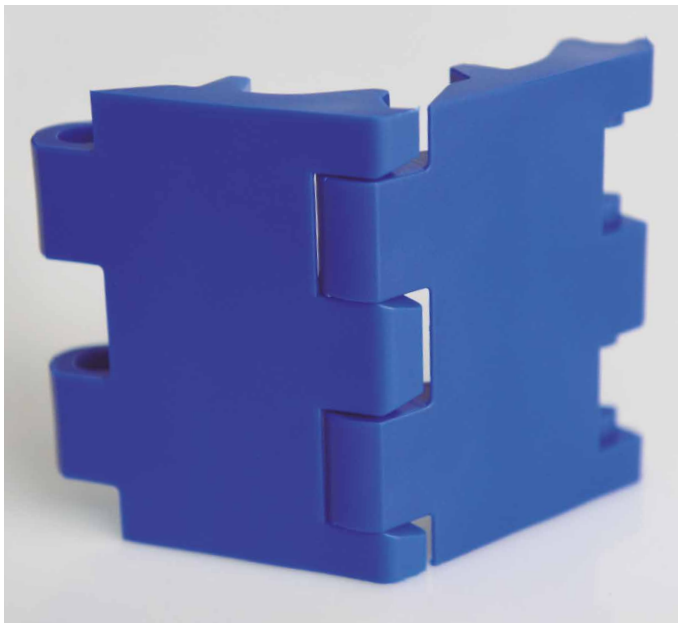

S E R I E S

Q50

F L A T T O P

The **quickbelts** modular conveyor belts are manufactured with heating plastics forming an interlaced structure injection pieces in an advanced design whose configuration makes them ideal support for **food transport and industrial product**.

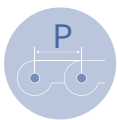

Pitch
50 mm



Thickness
16 mm



Open area
0 %

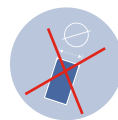

No rods



Product
take-off

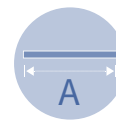



Belt width
Multiple of 40 mm



Q50 Flat Top
NSF 14159-3

quickbelts are manufactured in **Polyketone**, a **new polymer material** which provides the best possible performance for a wide range of applications.

Standar material of the belt	Temperature (°C)	Belt Resistance (kg/m)	Belt weight (kg/m ²)	Colour available	Food contact
PK		2.250 kg/m	11,85 kg/m ²	Blue, White	 



Excellent chemical resistance.
Resistance to chemical agents such as hydrocarbons, acids, etc.



Good tribological properties.
Wear, abrasion and friction resistance, and low-noise level.



Very high hydrolysis resistance.
Dimensional and properties' maintenance stability in humid and hot enviroments.

MINIMAL STRETCHING

Dimensional stability:

Minimal stretching at high loads.

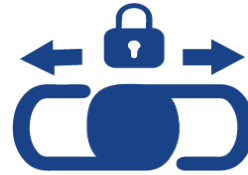

RESISTANCE

Max. load

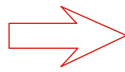

quickbelts
2.250 kg/m



Impact resistance



Wear resistance



Cut resistance

Superior to polyacetal (POM)

NON-STICK

Patented non-stick geometry

Patented geometry with moving parallel faces to facilitate product take-off on returns.

State-of-the-art non-stick polymers manufactured in POLYCETONE

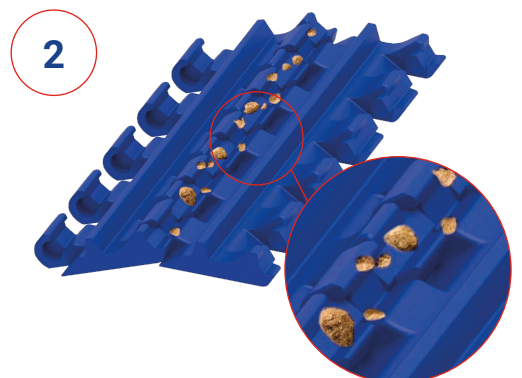
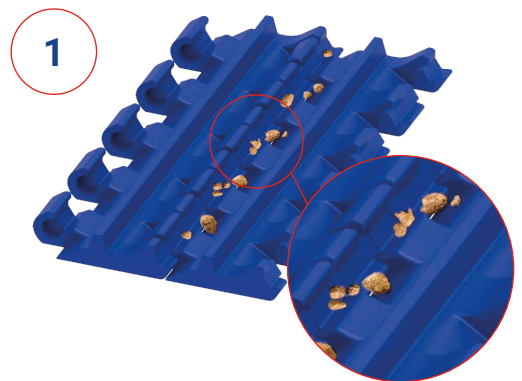

ACCESSORIES

SPROCKETS

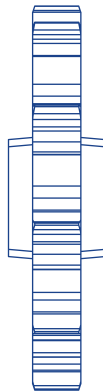
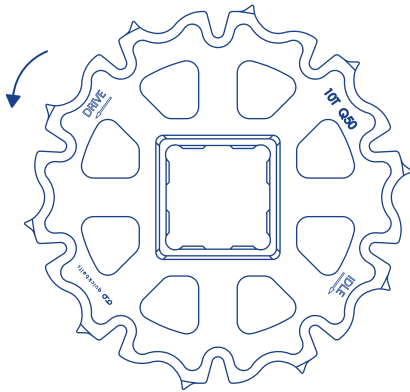

N° of teeth Z	Pitch diameter ø	Bore for square shaft	Hub width
8	130,6 mm	40 mm 1.5"	40 mm
10	161,8 mm	40 mm	
		1.5"	
		60 mm 2.5"	

DRIVE SHAFT

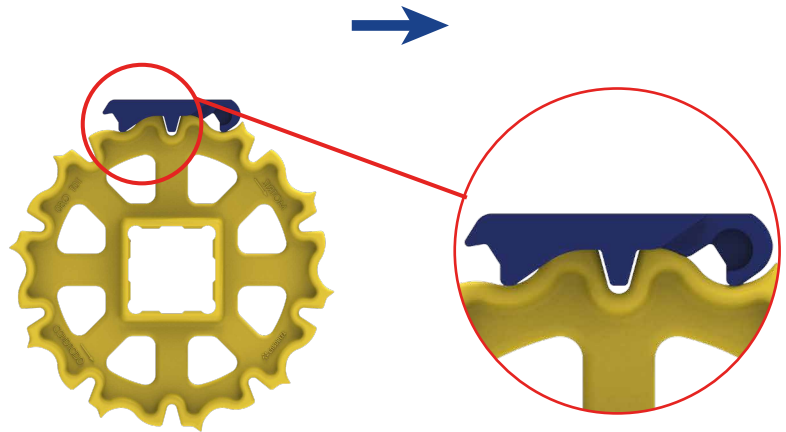
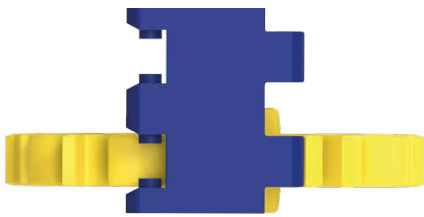

IDLE SHAFT

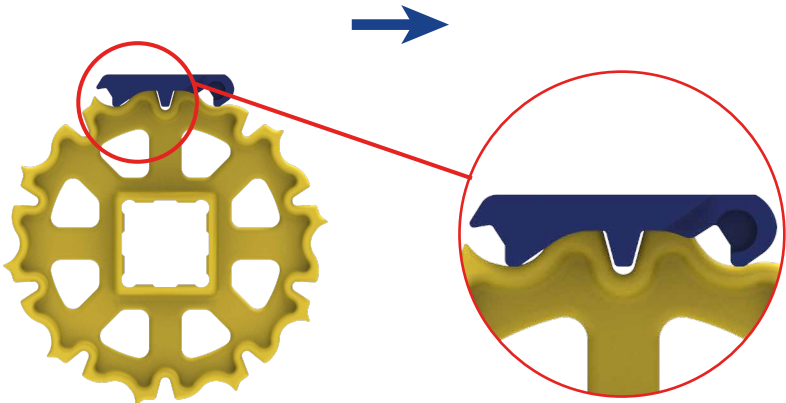
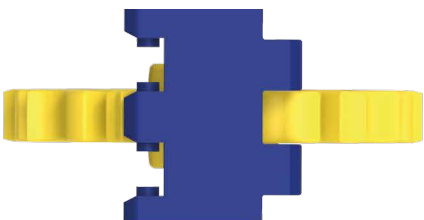

Sprockets for rounded shaft

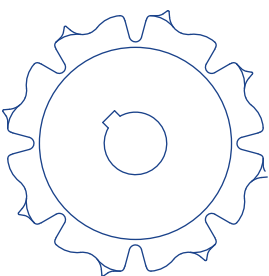

WITH KEYWAY

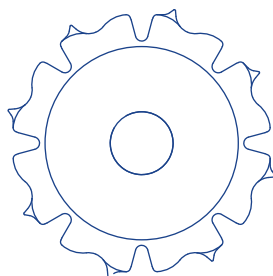

WITHOUT KEYWAY

We have plastic sprockets for round shaft with and without keyway. We also have sprockets to be used with **Motor Drum** in applications needing a special cleaning or in conveyors in which it is not possible to place the motor in the outside due to problems of space or safety.

CLE RETAINER RING

These rings are placed at every side of the central sprocket to fasten it to the shaft in order to avoid any lateral movements of the belt.

They are fixed by means of a set screw stuffed in the ring itself. One sprocket, duly fixed with 2 retaining rings, should be put in the centre.

Then you should place the same quantity of sprockets at every side of the central one but without any fixing, as they will absorb the possible belt expansions and contractions.

The same procedure should be carried out in both shafts.

STAINLESS STEEL AISI 316.

High range working temperature.

To square shaft of 40 mm, 1.5", 60 mm ó 2.5"

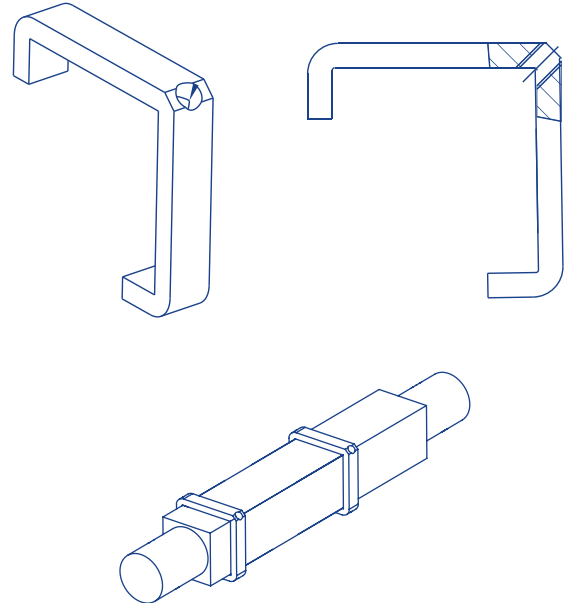

CLU RETAINER RING

The CLU Eurobelt retainer rings guarantee the fastening of the central sprocket on both drive and idle shafts.

The belt can expand or contract due to the temperature. The drive system of modular belts requires the central sprocket not to move axially both in the drive and the idle shafts. The rest of sprockets can slide freely on the shaft adapting to the possible changes of the belt, so that the correct position of the teeth is guaranteed.

POLYACETAL.

Working temperature: -40°C / +60°C

To square shaft of 40 mm or 1.5"

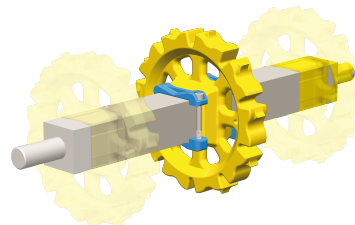

Fast and easy installation

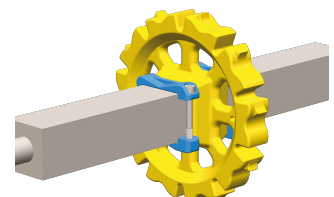
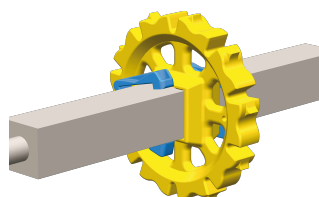
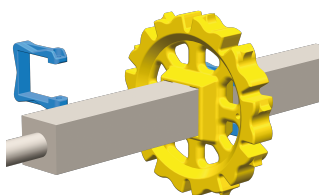

1. Direct installation without dismantling the shaft

2. Easy placing on the shaft by opening the ring.

3. Reliable closing of the ring by means of a screw and nut at a low cost.

WEARSTRIPS

The flat wearstrips are fastened by means of flatheaded plastic screws, which contributes to obtain a smooth surface free of any possibility of hooking.

The dimensions of those screws are: M 6 x 25 mm.

Due to their dovetail design, they can adapt to possible longitudinal contractions and expansions of the belt.

The wearstrips arrangement is an important factor in the life span of a conveyor belt. It should be chosen the most suitable configuration according to the transport needs. To calculate the quantity of supports, the weight of the product to be conveyed should be taken into account.

Dimensions	Materials
6 x 32 x 500	Polyethylene Polyacetal

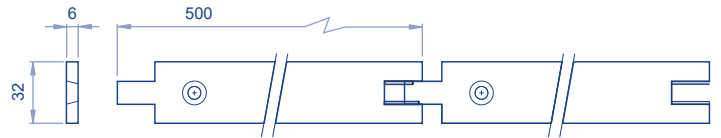

HOLD-DOWN PROFILES

To make the fastening and the support of the belt, EUROBELT has designed two types of hold-down profiles with different geometries, but with the same uses and services.

These profiles, with a low coefficient of friction, are placed between the belt and the structure of the conveyor, reducing the wear of the surfaces in contact, which contributes to prolong the life of the belt.

EUROBELT offers all the hold-down profiles in special polyethylenes with very good sliding properties and an excellent resistance to impact.

Accessories	Dimensions	Materials
Profiles in L	40 x 20 x 2.000	Polyethylene
	35 x 12 x 2.000	
Profiles in U	20 x 30 x 2.000	
	20 x 14 x 2.000	

Profiles in L

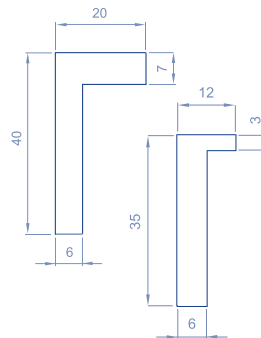

Profiles in U

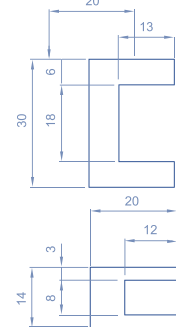

TECHNICAL DATA

MANUAL ASSEMBLY WITHOUT TOOLS

1

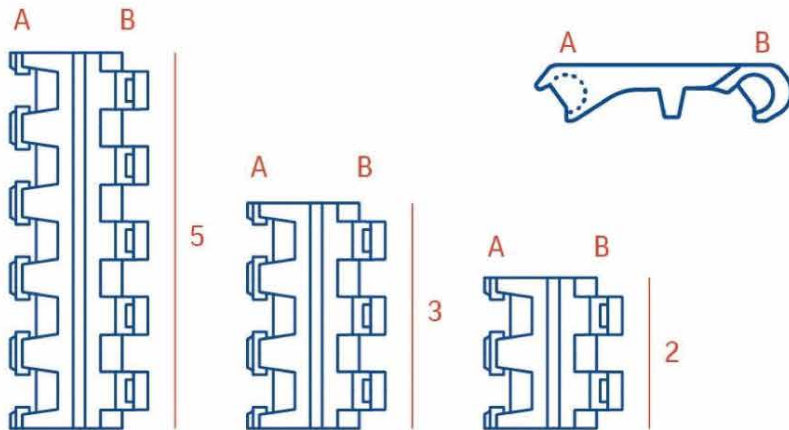

Its modular configuration allows you to configure the belt to suit your needs. On an easy and fast way.

To make the union between the rows of modules, these are provided with an articulated linker system without rod.

The modules, of different sizes, will be mounted alternately to give greater consistency to the belt.

2

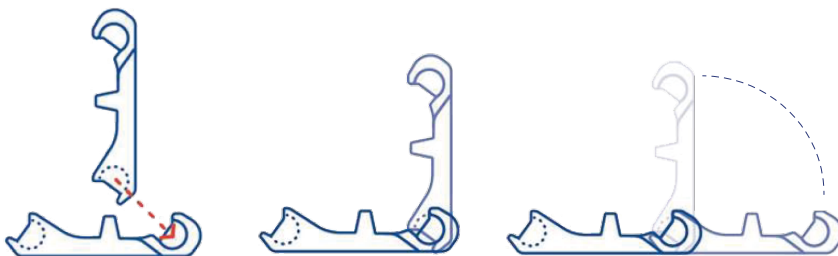

click!

3

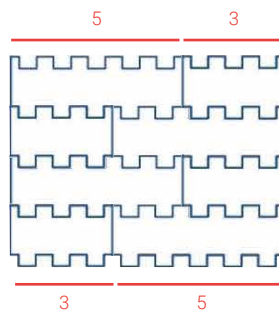
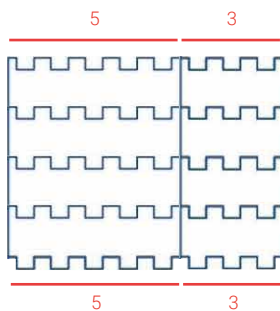

To take into account

1



Use a flat surface.

2



It is not necessary to use tools

3



You must wear safety gloves

4



Contact our technical service

CONSTRUCTION DATA

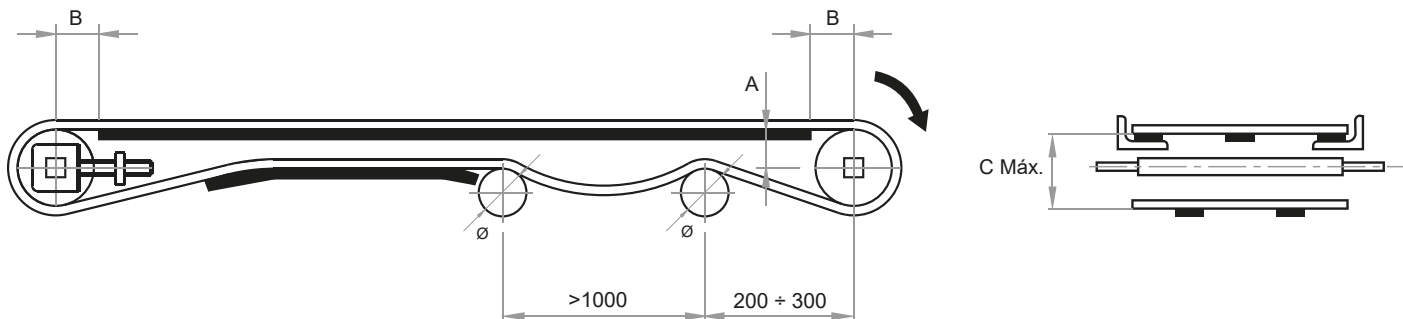

Nº of teeth Z	Ø Pitch	A	B Max.	C Max.	Ø min
8	130,6	58	60	135	100
10	161,8	72	76	165	100

[A] Distance between the sliding surface of the belt and the centre of the shaft.

[B] Distance between the vertical of the shaft and the beginning of the sliding surface.

[C] Distance between the sliding surface of the belt and the support of the return way.

[D] Diameter of support rollers.

TABLE OF SPROCKETS AND WEARSTRIPS

To calculate the necessary minimum quantity of sprockets for the drive shaft as well as for the idle one, the next formula has been used:

$$\text{MINIMUM QUANTITY} = \frac{\text{BELT WIDTH (mm)}}{150 \text{ mm}}$$

This amount must always be odd.
To calculate the quantity of supports, the weight of the product to be transported must be taken into account.

The distance between supports should not exceed 230mm in the transport way or 300mm in the return way.

Belt nominal width (mm)		Minimum quantity of sprockets per shaft	Minimum quantity of wearstrips	
			Transport way	Return way
40	150	1	2	2
160	450	3	2	2
460	750	5	3	2
760	1.050	7	5	3
1.060	1.350	9	6	4
1.360	1.650	11	7	5

CUSTOMER SERVICE

DELIVERY TIME

No more waiting for your belts to be manufactured, you can order the parts and have them assembled at your facility in record time.



Length:	200 mm	120 mm	40 mm
Links:	5	3	1
Units per box:	104	156	104

CLEANING AND MAINTENANCE

Our modular belts, Quickbelts, are designed to guarantee a fast and efficient cleaning. Internal cleaning of modules: By rotating the band on the sprockets, the joinings between their modules are opened, allowing the input of the water jet at pressure.

Our exclusive design with crossing channels allows the pressure water jet to walk all the return width of the belt, ejecting all particles of retained products.

To clean the space between sprockets the jet of water under pressure passes through the lateral holes of the same.

Finally, with the pressure sweep of the water jet, we will proceed to remove the particles adhered to the surface of the belt.

One of the most important characteristics of the system of plastic modular bands is its low maintenance.

With a minimum maintenance preventive expense, the belt can operate without interruption, until wear of the material itself because of the friction with the fixed parts of the conveyor it is convenient to decide on its replacement to avoid unscheduled stops.

In the event of an accident (hitch or breakage), your repair will only need a few minutes, for the replacement of the damaged modules and no special tools of any kind are necessary.

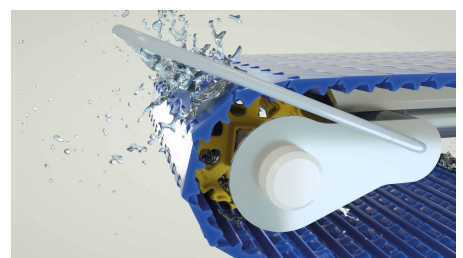
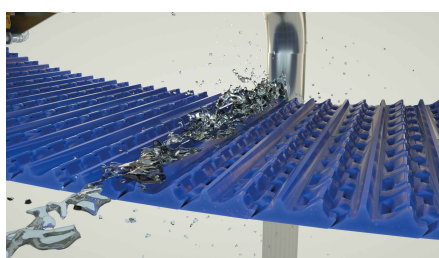
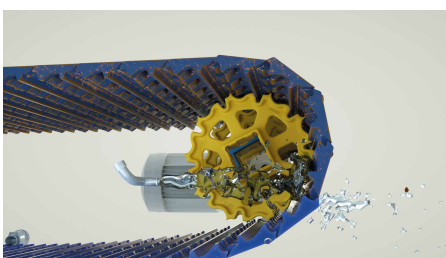

GUARANTEE AND LIMITATION OF LIABILITY

EUROBELT elements are guaranteed for a period of one year from the date of shipment with respect to the repair or substitution of any component whose materials or manufacture is defective, provided it is demonstrated that the work has been done under normal conditions of use.

No other expressed or implicit guarantee is given, unless it were set down in writing and approved by the manufacturer.

EUROBELT elements are manufactured with plastic materials. Consequently, their direct exposure to fire or to higher temperatures than those indicated can produce their deflagration together with the emission of toxic fumes. Any use of the EUROBELT products has to observe the regulations and rules prevailing and the user is the only responsible to make observe these regulations when incorporating those products into any machine.

The data included here are of informative nature. Their applicability to the design of any installation is not guaranteed.

The manufacturer does not assume any responsibility for the repercussions derived from the use of his products, whether it is based or not on the information herein.

CONTACT

Eurobelt offers its customers different communication channels, through which they can solve all their doubts related to our solutions in modular belts, as well as access to our recommendations when designing a complete internal transport system.

To the already traditional channels of communication, telephone, fax and email we have also incorporated the WhatsApp Channel and the Eurobelt AR Catalogue app, not forgetting our website, **www.eurobelt.com**, in whose Client Area you can download numerous documentation, diagrams and technical data of all our products.

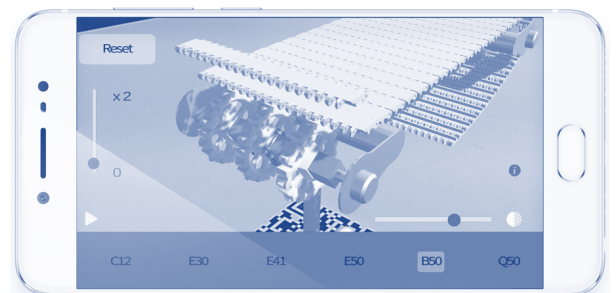

PATENTED

quickbelts



Thanks to the new modular belt generation, with just one click you could assembly the belt yourself.



**DO IT QUICK
DO IT YOURSELF
DO IT WITH
quickbelts**

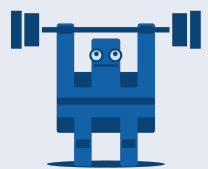

Great resistance.
Very limited elongations.

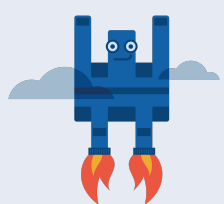

Immediate delivery time.

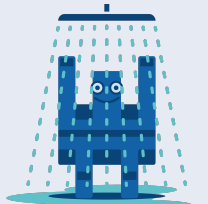

Easy to clean.

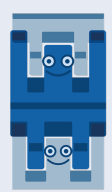

Quick and easy to assemble.



More cost-effective.

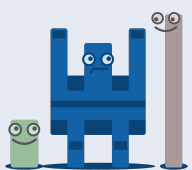

Stock reduction.
(single parts)



Product take-off.

EUROBELT

Topacio, 41 47012 - Valladolid (SPAIN)
Phone: +34 983 217 480
e-mail: after@eurobelt.com

quickbelts
www.quick-belts.com

