



GÜVENİLİR ÇÖZÜM ORTAĞINIZ RELIABLE SOLUTION PARTNER



# EFATECH

2014'den bu yana üretim bandı için EFATECH makinalarını tercih eden müşterimize, makinalarımızı daha da iyi performans ve dayanıklılıkla üretmemiz için bizimle olan tedarikçilerimize teşekkür ederiz.

*We would like to thank, Our Customers, who prefer EFATECH machines for their production lines and Our Suppliers, for being with us by helping us to manufacture our machines with a better performance and durability since 2014.*





## DAHA HIZLI ÜRETİM İÇİN

Efatech sahip olduğu mühendislik bilgisi ve deneyim ile tekstil otomasyon sistemlerinin getirdiği avantajları proje, eğitim, bakım ve servis hizmetlerini en uygun biçimde sektörün hizmetine sunmaktadır. Deneyimi sayesinde sektörün inceliklerini, gereklerini ve ihtiyaçlarını bilerek, uzman kadrosu, verimli iş planlama yapısı ve AR-GE'ye dayalı projeleri ile sektörel ihtiyaçları karşılayacak en doğru çözümleri üretmektedir.

Efatech müşteri memnuniyeti, profesyonel teknik destek, güvenli hizmet anlayışı ile tekstil otomasyon sis-

teminde müşterilerinin tam memnuniyetini sağlamak için 2014 yılından beri ilk günkü heyecan ve istekle çalışmaktadır. Tekstil otomasyon sistemlerinde hız, hassasiyet, kolay kullanım, esnek yapı, değiştirilebilirlik, sağlamlık gibi parametreleri maksimum düzeye çıkarmaktadırlar.

Profesyonel kadrosu ile sürekli artan bilgi birikimini sistem çözümlerinde müşterilerinin hizmetine sunmaktadır. Yüksek kalite anlayışı ile en iyi müşteri memnuniyetini sağlamak için çözümler sunmayı vizyon edinmiştir.

## FOR FASTER PRODUCTION

Efatech puts the advantages of textile automation systems at project, education, maintenance and repair cares into sector's disposal with the engineer knowledge and experience it has. Provides the sectoral requirements with projects based on research & development and by knowing sectoral points, requirements and necessities, expert staff, productive business planning through the experience.

Efatech has maintained enthusiasm and willingness from the very first day for its customers' full satisfaction at textile automation systems with the attitude of safe service, prof-

essional technical support and customers' pleasure, since 2014. Efatech provides the highest level in parameters like speed, accuracy, ease in use, flexibility, alterability, robustness in textile automation systems.

We present our Professional staff and constantly developing knowledge in system analysis to the service of our customers. The prior vision of our company is to provide customer satisfaction with an understanding of high quality in the solutions we offer.



YENİ Kalite Standartları

## Tamamı Alüminyum Gövde

Paça otomatına özel olarak, tasarımdan üretimine Efatech tarafından geliştirilmiştir.

NEW Quality Standarts

## Aluminum Body

Special sewing head for bottom hemming.  
Designed and made by Efatech.



**PAÇA** Otomati  
İnce Kumaş - Chino

**PC-40V3C**

**BOTTOM HEMMING** Machine  
For Chino and Casual Pants



SAATTE 250 PANTOLON  
250 PANTS PER HOUR

**EFA TECH**  
SEWING AUTOMATION SYSTEMS

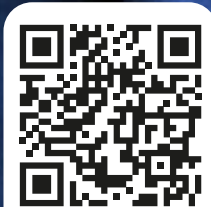

  
ALÜMİNYUM GÖVDE  
ALLUMINUM BODY

  
DOKUNMATİK KONTROL  
TOUCH CONTROL

  
MOTION KONTROL  
MOTION CONTROL

  
DİJİTAL ADIM AYARI  
DIGITAL STITCH LENGTH

  
BAĞIMSIZ ÇEKİRME  
INDEPENDENT PULLERS



- Büyük mekik ile daha uzun süre çalışma
- Tek noktadan ayarlanabilen paça genişliği.
- Pnömatik ayarlanabilir kumaş gerdirme.
- Tek noktadan ayarlanabilen paça kat genişliği.
- Dokunmatik renkli kontrol paneli, Dijital olarak dikiş adımlarını çok hassas ayarlayabilme, Çoklu ek görebilme, Yaptığı işi sayabilme
- Merdane ve palet tipi servo motor çektirme sistemi

- It can operate longer with large hook.
- Easy adjustment of fabric guide for different hem diameters.
- Invidual pressure adjustment for fabric tensioners.
- Easy adjustment of hem folding width from single knob.
- Colored control panel with touch screen, Sewing steps can be adjusted digitally, Can see multiple attachment, Can count the jobs completed.
- Cylinder and belt servo motor puller system.

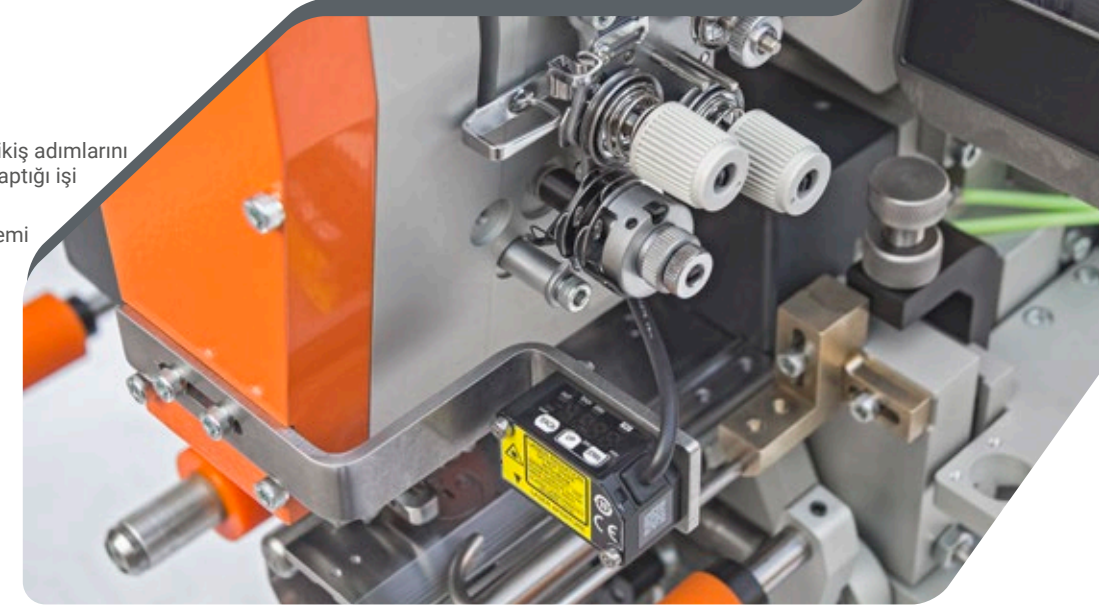

### Teknik Özellikler Technical Specifications

OPTIONS	PC-40V3C FOR CHINO FABRICS (LOCKSTITCH TYPE)
SEWING HEAD	DESIGNED BY EFATECH -ALUMINIUM SEWING HEAD
PRODUCTION CAPACITY	230-250 PIECES/HOUR
MAX SEWING SPEED	3500 rpm
PNEUMATIC GROUP	SMC
AUTOMATION GROUP	MITSUBISHI
STITCHES PER CM	1-10 STITCHES (CAN BE SET FROM TOUCH PANEL)
HEMMING PARAMETERS	1 TO 4 CM WIDTH 14 TO 55 CM LENGHT
NOISE	MACHINE NOISE WHEN MACHINE OPERATED 3500 RPM Lpa < 84dB
BOTTOM PULLER	ADJUSTABLE SERVO MOTOR
SEWING HEAD MOTOR	DIRECT DRIVE SERVO MOTOR
TOP PULLER	ADJUSTABLE SERVO MOTOR
VOLTAGE	220 V
POWER	1.5 kW / 10 A
AIR PRESSURE	6-7 BAR
NET WEIGHT	125 KG
GROSS WEIGHT	160 KG

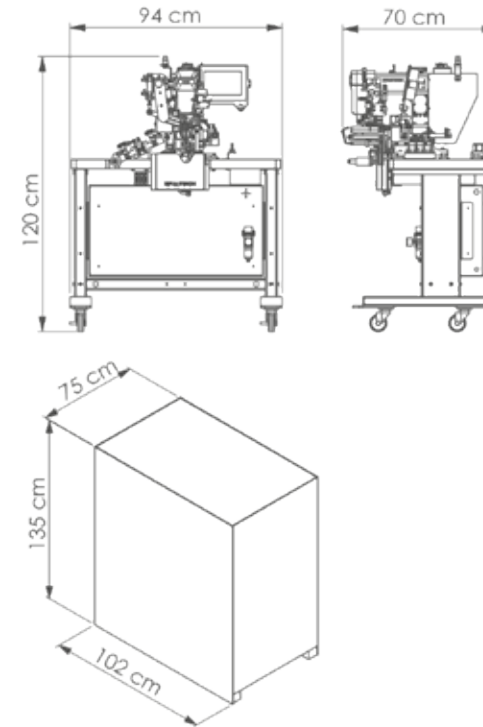





SAATTE 250 PANTOLON  
250 PANTS PER HOUR

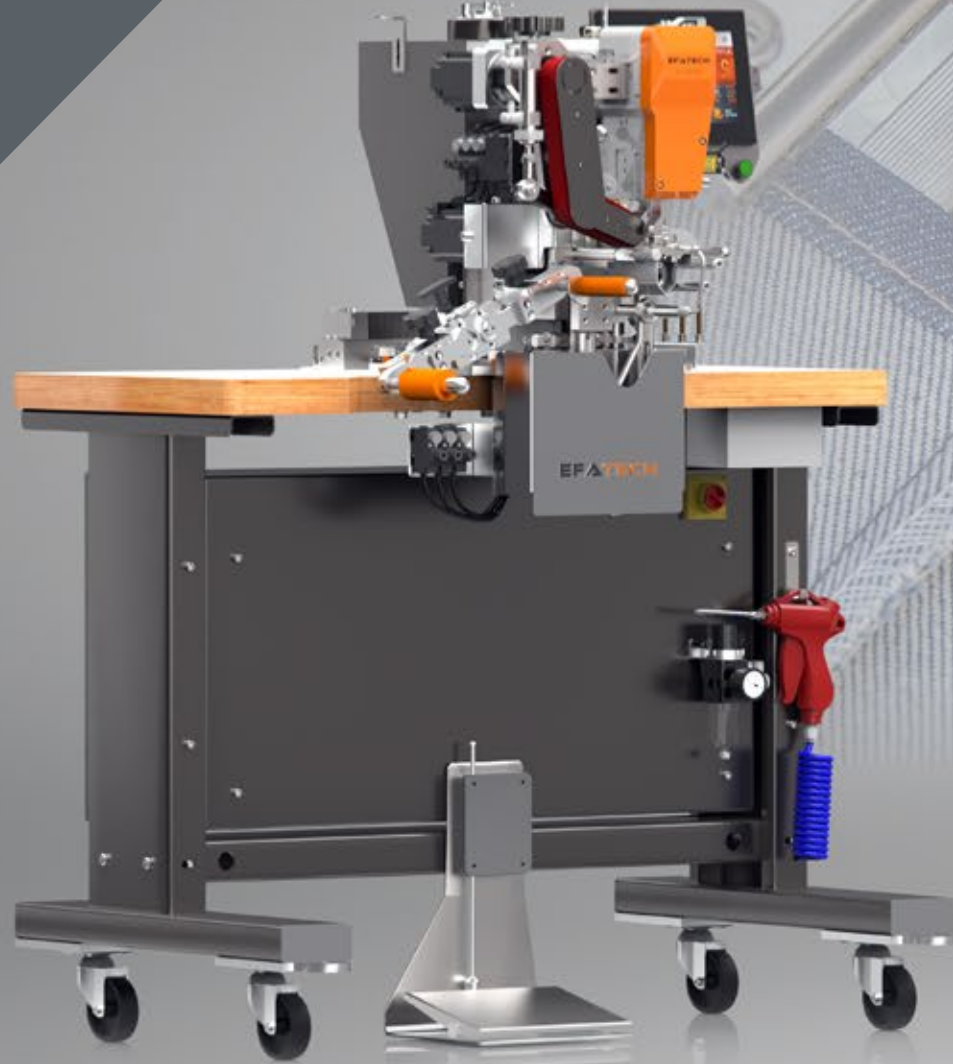

**PAÇA** Otomatı  
Kalın Kumaş- Denim

**PC-40V3H**

**BOTTOM HEMMING**  
Machine  
Heavy Duty Fabric

-  ALÜMİNYUM GÖVDE  
ALLUMINUM BODY
-  DOKUNMATİK KONTROL  
TOUCH CONTROL
-  MOTION KONTROL  
MOTION CONTROL
-  DİJİTAL ADIM AYARI  
DIGITAL STITCH LENGTH
-  PALETLİ ÇEKTİRME  
PULLEY EXTRACTION





- Büyük mekik ile daha uzun süre çalışma
- Tek noktadan ayarlanabilen paça genişliği.
- Pnömatik ayarlanabilir kumaş gerdirme.
- Tek noktadan ayarlanabilen paça kat genişliği.
- Dokunmatik renkli kontrol paneli, Dijital olarak dikiş adımlarını çok hassas ayarlayabilme, Çoklu ek görebilme, Yaptığı işi sayabilme
- Palet tipi servo motor çekirme sistemi

- It can operate longer with large hook
- Easy adjustment of fabric guide for different hem diameters.
- Individual pressure adjustment for fabric tensioners
- Easy adjustment of hem folding width from single knob
- Colored control panel with touch screen, Sewing steps can be adjusted digitally, Can see multiple attachment, Can count the jobs completed
- Belt type servo motor puller system

Lazer Ek Algılama.  
Laser Joint Detection.

Palet tipi servo motor kontrollü üst çekirme

Servo drive belt puller system

### Teknik Özellikler Technical Specifications

OPTIONS	PC-40V3H FOR DENIM FABRICS (LOCKSTITCH TYPE)
SEWING HEAD	DESIGNED BY EFATECH -ALUMINIUM SEWING HEAD
PRODUCTION CAPACITY	230-250 PIECES/HOUR
MAX SEWING SPEED	3500 rpm
PNEUMATIC GROUP	SMC
AUTOMATION GROUP	MITSUBISHI
STITCHES PER CM	1-10 STITCHES (CAN BE SET FROM TOUCH PANEL)
HEMMING PARAMETERS	1 TO 4 CM WIDTH 14 TO 55 CM LENGHT
NOISE	MACHINE NOISE WHEN MACHINE OPERATED 3500 RPM Lpa < 84dB
BOTTOM PULLER	ADJUSTABLE SERVO MOTOR
SEWING HEAD MOTOR	DIRECT DRIVE SERVO MOTOR
TOP PULLER	ADJUSTABLE SERVO MOTOR
VOLTAGE	220 V
POWER	1.5 kW / 10 A
AIR PRESSURE	6-7 BAR
NET WEIGHT	125 KG
GROSS WEIGHT	160 KG

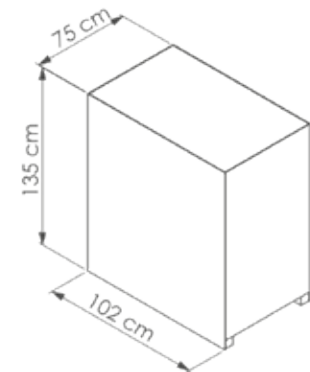
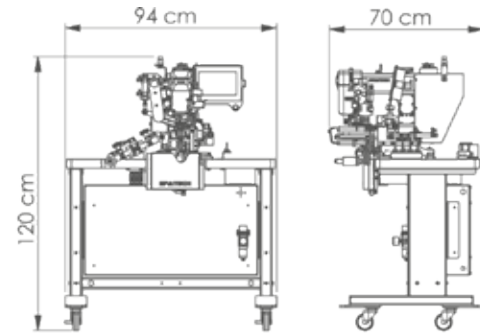



# ETİKET Otomati

Tek İstasyon Kıvrımalı Etiket Otomati

## LBS-1V1F

### LABEL Sewing

Single Station Label Sewing Machine  
with Folding Option

- 1 Adet Etiket İstasyonu.
- Düz ve Kıvrımalı Etiket Dikebilme
- 1 adet Punteriz dikiş istasyonu
- Saten etikete uygun ultrasonik kesim
- Dijital ölçü
- Kolay kullanım
- Step motor kontrollü etiket sürme

- 1 Label Station.
- Straight & Folded Label Sewing
- 1 Bartack Sewing Machine
- Ultrasonic cutting for satin label
- Digital measurement
- Easy to use
- Step motor controlled label pulling

ULTRASONIC CUTTING







SAATTE 800 ETİKET  
800 LABELS PER HOUR



EFATECH  
SEWING AUTOMATION SYSTEMS



-  DOKUNMATİK KONTROL  
TOUCH CONTROL
-  ULTRASONİK  
ULTRASONIC
-  DİJİTAL ÖLÇÜ AYARI  
DIGITAL MEASUREMENT
-  MAKSİMUM DEVİR  
MAXIMUM SPEED



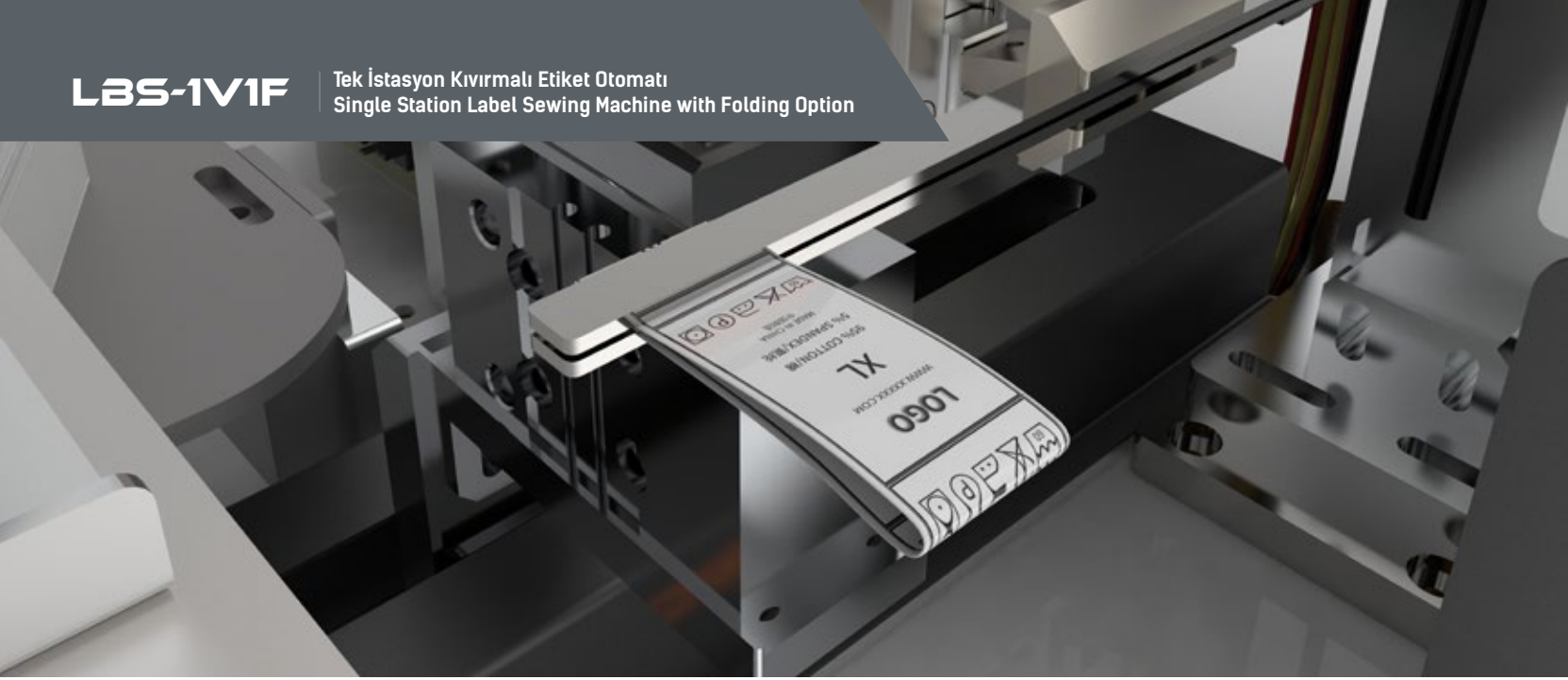

## Teknik Özellikler Technical Specifications

SEWING HEAD	40X30 MM BARTACKING MACHINE,AUTOMATIC SEWING
LABEL MOVEMENT	STEP MOTOR CONTROL
CUTTING TYPE	20 KHZ ULTRASONIC CUTTING SYSTEM
CUTTIN POINT DETECTION	CONTRAST SENSOR
LABEL WIDTH	Min: 15 mm Max: 45 mm
LABEL LENGTH	Straight Labels: Min:20 mm Max: 90 mm Folded Labels:Min:20 mm Max= 90 mm
LABEL STATION NUMBER	1 STATIONS ( STANDARD)
PRODUCTION CAPACITY	800 PCS/HOUR
MAX SEWING SPEED	3500 rpm
PNEUMATIC GROUP	SMC
AUTOMATION GROUP	MITSUBISHI
NOISE	MACHINE NOISE WHEN MACHINE OPERATED 3500 RPM Lpa < 84dB
VOLTAGE	220 V
POWER	2 Kw
AIR PRESSURE	6-7 BAR
NET WEIGHT	225 KG
GROSS WEIGHT	310 KG

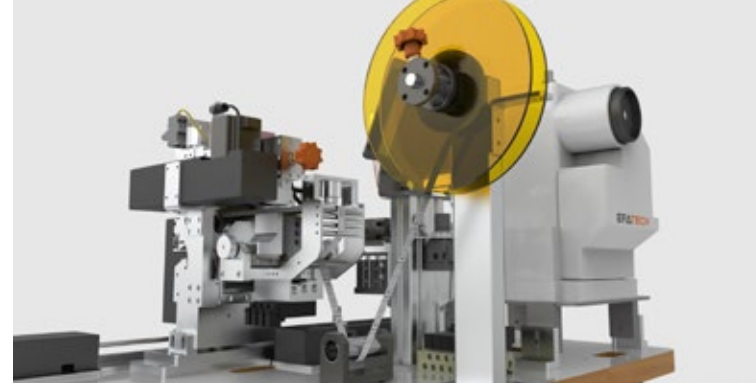
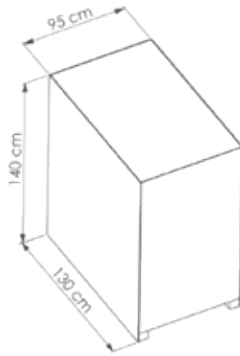
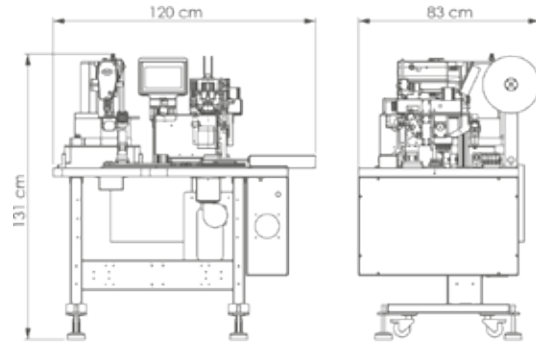
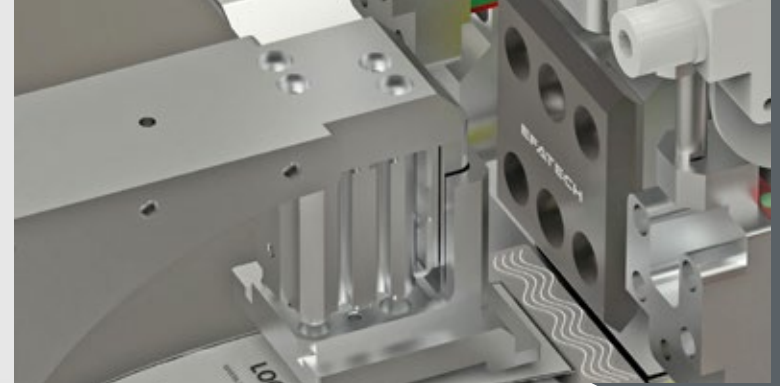
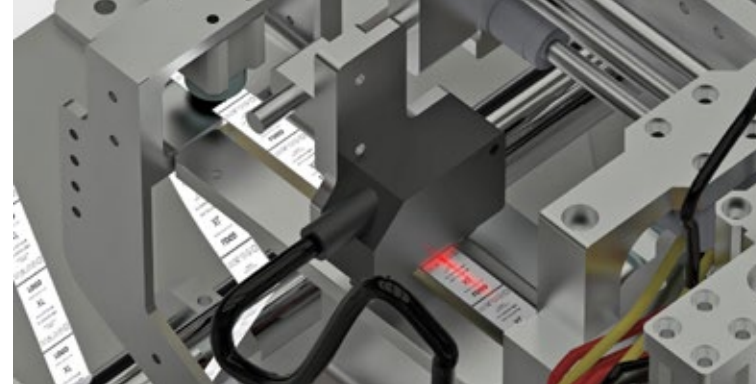
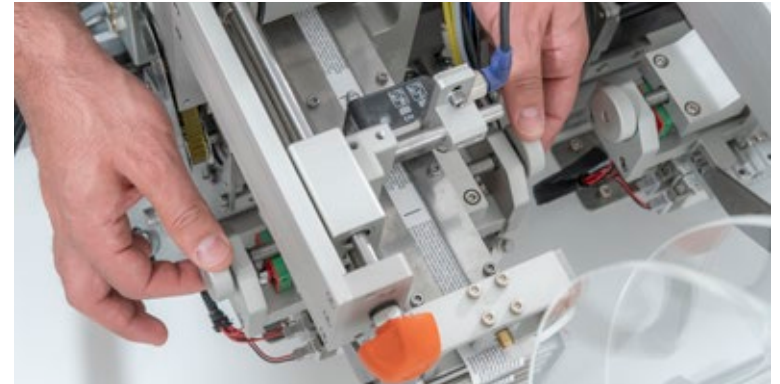
Ayarlanabilir bollandırma sistemi.  
Adjustable loosening system.Ultrasonik kesim.  
Ultrasonic cutting.Kesim çizigisi algılama.  
Cutting line detectionDokunmatik kontrol paneli.  
Touch control panel .Bağımsız ayarlanabilir etiket hizalama sistemi.  
Adjustable label positioning system.



# ETİKET Otomatı

Düz Etiket Birleştirme ve Dikme Otomatı

## LBS-6V1

### LABEL Sewing

Straight Label Collecting and Sewing Machine

ULTRASONIC CUTTING



SAATTE 1000 ETİKET  
1000 LABELS PER HOUR



- 6 adet etiket istasyonu, opsiyonel olarak etiket istasyonları artırılabilir.
- 1 adet Punteriz dikiş istasyonu
- Saten etikete uygun ultrasonik kesim
- Dijital ölçü
- Operatörsüz iş hazırlama modu (tam otomatik)
- Kolay kullanım
- İstenilen istasyonların kapatılabilmesi
- Step motor kontrollü etiket sürme
- Otomatik İstifleme

- 6 label stations, optional label stations can be increased.
- 1 Bartack Sewing Machine
- Ultrasonic cutting for satin label
- Digital measurement
- Full automatic, running without operator
- Easy to use
- Any stations can be closed
- Step motor controlled label pulling
- Automatic Stacking System

EFATECH  
SEWING AUTOMATION SYSTEMS



DOKUNMATİK KONTROL  
TOUCH CONTROL

ULTRASONİK  
ULTRASONIC

DİJİTAL ÖLÇÜ AYARI  
DIGITAL MEASUREMENT

MAKSİMUM DEVİR  
MAXIMUM SPEED







Tam otomatik istifleme sistemi.

Automatic stacking system.

### Teknik Özellikler Technical Specifications

SEWING HEAD	40X30 MM BARTACKING MACHINE,AUTOMATIC SEWING
LABEL MOVEMENT	STEP MOTOR CONTROL
CUTTING TYPE	20 KHZ ULTRASONIC CUTTING SYSTEM
CUTTIN POINT DETECTION	CONTRAST SENSOR
LABEL WIDTH	Min: 15 mm Max: 45 mm
LABEL LENGTH	Straight Labels: Min:20 mm Max: 140 mm
LABEL STATION NUMBER	6 STATIONS ( STANDARD)
PRODUCTION CAPACITY	1000 PCS / HOUR
MAX SEWING SPEED	3200 rpm
PNEUMATIC GROUP	SMC
AUTOMATION GROUP	MITSUBISHI
NOISE	MACHINE NOISE WHEN MACHINE OPERATED 3500 RPM Lpa < 84dB
VOLTAGE	220 V
POWER	6 Kw
AIR PRESSURE	6-7 BAR
NET WEIGHT	600 KG
GROSS WEIGHT	800 KG

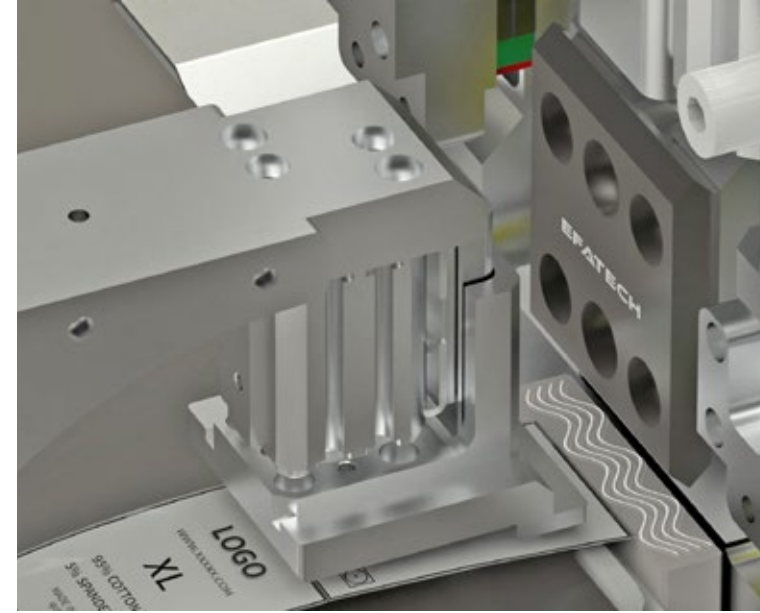
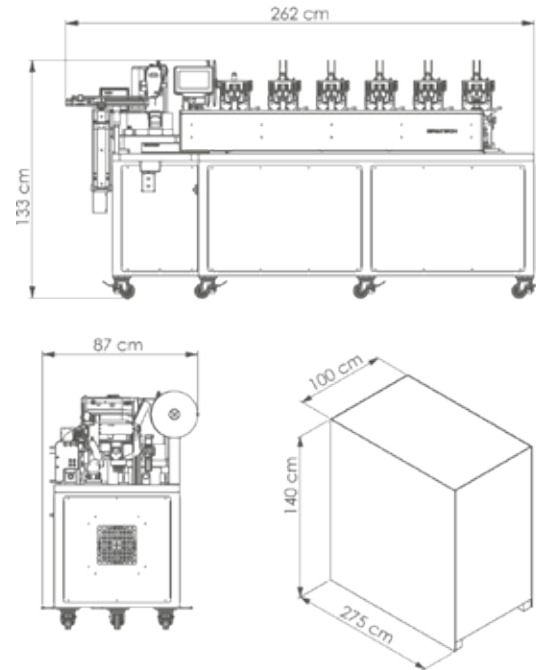

Ultrasonik kesim.

Ultrasonic Cutting.

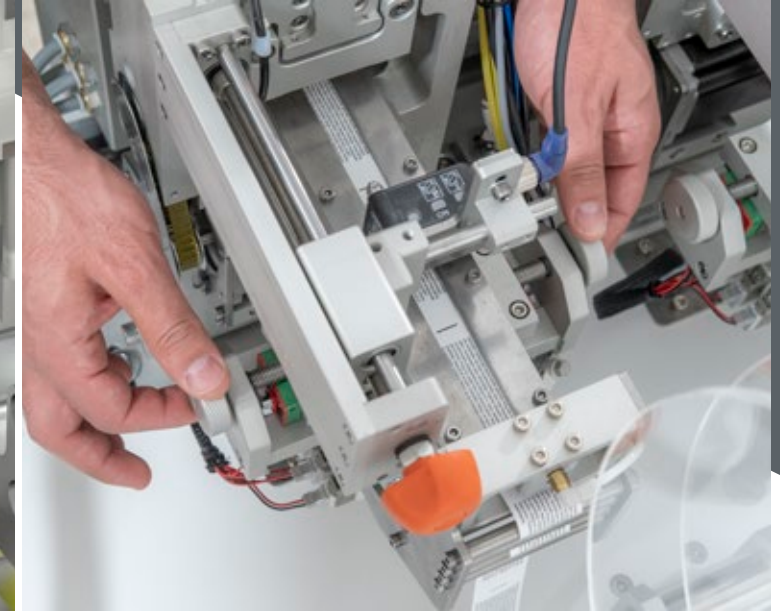

Bağımsız ayarlanabilir etiket hizalama sistemi.

Adjustable label positioning system.



Kesim çizigisi algılama.

Cutting line detection



Ayarlanabilir bollandırma sistemi.

Adjustable loosening system.



# ASKILIK Otomati

Ultrasonik Saten Askılık Otomati - Full Versiyon

## PD-X10SCF

### ULTRASONIC CUTTING

## LOOP Attacher

Ultrasonic Ribbon  
Loop Attacher  
Full Version



SAATTE 1250 ASKI  
1250 LOOPS PER HOUR



**EFATECH**  
SEWING AUTOMATION SYSTEMS



DOKUNMATİK KONTROL  
TOUCH CONTROL



ULTRASONİK  
ULTRASONIC



DİJİTAL ÖLÇÜ AYARI  
DIGITAL MEASUREMENT



MAKSİMUM DEVİR  
MAXIMUM SPEED

Operatörsüz Otomatik İş Hazırlama  
Preparing Mode without Operator

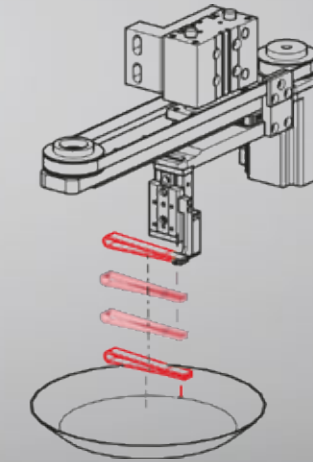

Omuzdan Omuza  
Shoulder to Shoulder

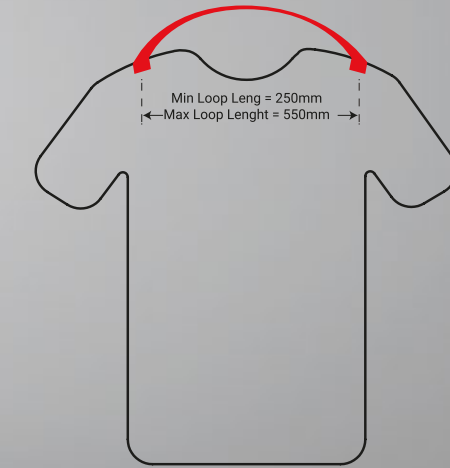

Temiz Kıvrırma  
Clean Folding Mode

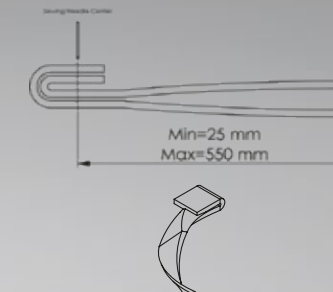

Temiz Kıvrımsız  
Without Clean Folding Mode

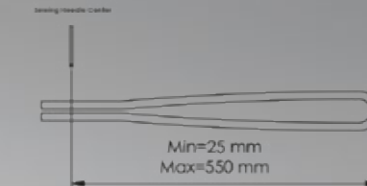





Ultrasonik Kesim  
 Ultrasonic cutting

Ek Yeri Algılama Sistemi  
 Joint Detection System

**Teknik Özellikler Technical Specifications**

Options	CLEAN FOLDING- & WITHOUT CLEAN FOLDING & SHOULDER TO SHOULDER SEWING & PREPARING RIBBON LOOP OPTIONS AT THE SAME TIME
SEWING HEAD	40X30 MM BARTACKING MACHINE,AUTOMATIC SEWING
PRODUCTION CAPACITY	1250 PIECE/HOUR
MAX SEWING SPEED	3500 rpm
PNEUMATIC GROUP	SMC
AUTOMATION GROUP	MITSUBISHI
NOISE	MACHINE NOISE WHEN MACHINE OPERATED 3500 RPM Lpa < 84dB
RIBBON CUTTING UNITE	ULTRASONIC CUTTING
VOLTAGE	220 V
POWER	2 kW / 10 A
AIR PRESSURE	6-7 BAR
NET WEIGHT	205 KG
GROSS WEIGHT	280 KG

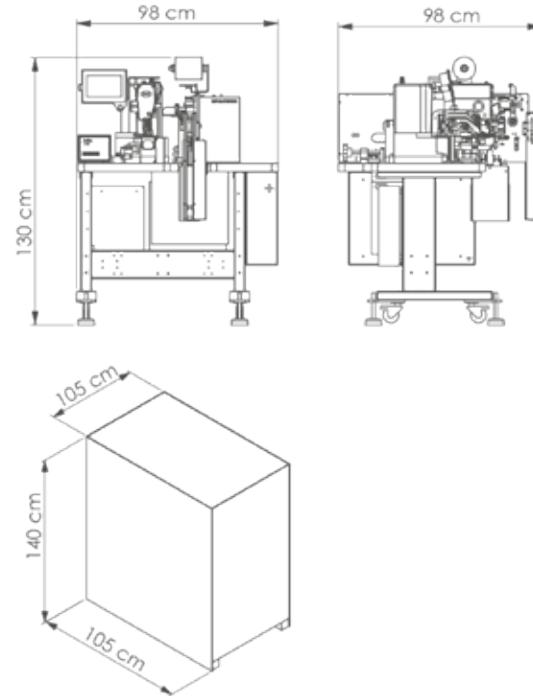



# ASKILIK Otomati

Ultrasonik Saten Askılık Otomati - Standart Model

## PD-X10SC

### ULTRASONIC CUTTING

# LOOP Attacher

Ultrasonik Ribbon Loop Attacher Standart Model



SAATTE 1250 ASKI  
1250 LOOPS PER HOUR



Temiz Kıvrmasız  
Without Clean Folding Mode

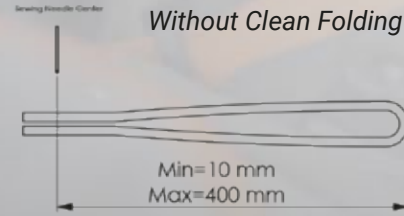

Temiz Kıvrırma  
Clean Folding Mode

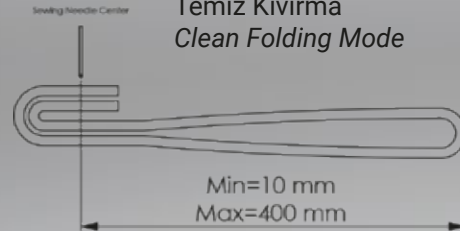

DOKUNMATİK KONTROL  
TOUCH CONTROL

ULTRASONİK  
ULTRASONIC

DİJİTAL ÖLÇÜ AYARI  
DIGITAL MEASUREMENT

MAKSİMUM DEVİR  
MAXIMUM SPEED



Ultrasonik Kesim  
Ultrasonic cutting



Ek Yeri Algılama Sistemi  
Joint Detection System

#### Teknik Özellikler Technical Specifications

Options	STRAIGHT AND CLEAN FOLDED RIBBON LOOP ATTACHER
SEWING HEAD	40X30 MM BARTACKING MACHINE,AUTOMATIC SEWING
PRODUCTION CAPACITY	1250 PIECE/HOUR
MAX SEWING SPEED	3500 rpm
PNEUMATIC GROUP	SMC
AUTOMATION GROUP	mitsubishi
NOISE	MACHINE NOISE WHEN MACHINE OPERATED 3500 RPM Lpa < 84dB
RIBBON CUTTING UNITE	ULTRASONIC CUTTING
VOLTAGE	220 V
POWER	2 kW / 10 A
AIR PRESSURE	6-7 BAR
NET WEIGHT	190 KG
GROSS WEIGHT	260 KG

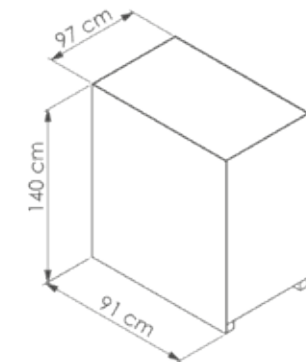
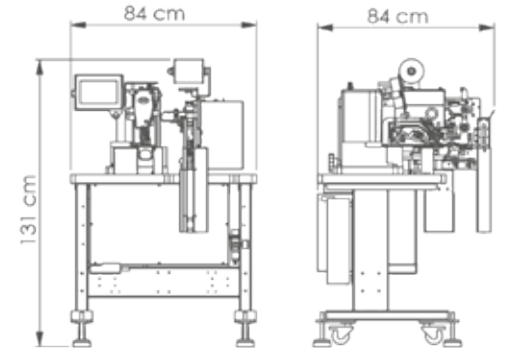



# ASKILIK Otomati

Soğuk Kesim Askılık Otomati (Ekonomik Model)

## PD-X10CC

COLD CUTTING

## LOOP Attacher

Cold Cutting Ribbon Loop Attacher (Eco Model)



SAATTE 1250 ASKI  
1250 LOOPS PER HOUR



Temiz Kıvrımsız  
Without Clean Folding Mode

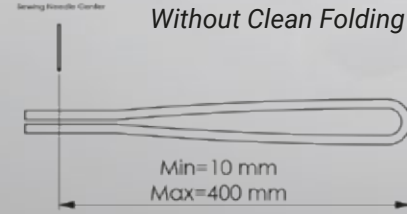

Temiz Kıvrırma  
Clean Folding Mode

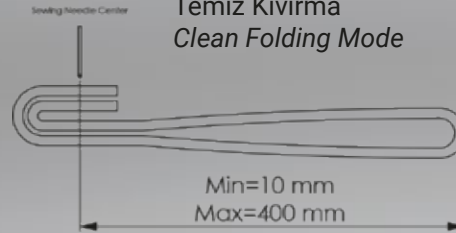

DOKUNMATİK KONTROL  
TOUCH CONTROL



DİJİTAL ÖLÇÜ AYARI  
DIGITAL MEASUREMENT



MAKSİMUM DEVİR  
MAXIMUM SPEED

EFATECH  
SEWING AUTOMATION SYSTEMS



Soğuk Kesim  
Cold Cutting



Ek Yeri Algılama Sistemi  
Joint Detection System

### Teknik Özellikler Technical Specifications

Options	CLEAN FOLDING- FLAT FOLDING-S OPTIONS AT THE SAME TIME
SEWING HEAD	40X30 MM BARTACKING MACHINE, AUTOMATIC SEWING
PRODUCTION CAPACITY	1250 PIECE/HOUR
MAX SEWING SPEED	3500 rpm
PNEUMATIC GROUP	SMC
AUTOMATION GROUP	MITSUBISHI
NOISE	MACHINE NOISE WHEN MACHINE OPERATED 3500 RPM Lpa < 84dB
RIBBON CUTTING UNITE	COLD CUTTING - KNIFE
VOLTAGE	220 V
POWER	1 kW / 10 A
AIR PRESSURE	6-7 BAR
NET WEIGHT	175 KG
GROSS WEIGHT	240 KG

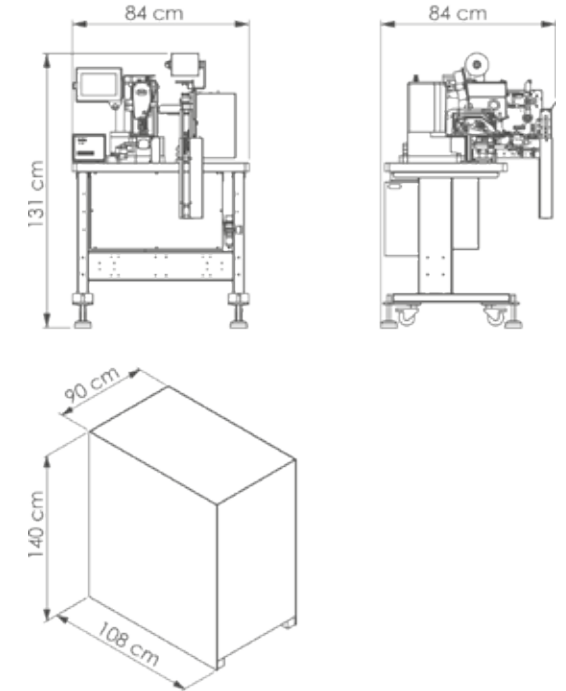



# ASKILIK Otomati

Soğuk Kesim Ters Askılık Otomati (Brit Otomati)

## PD-X10RCC

COLD CUTTING

## LOOP Attacher

Cold Cutting Reverse Loop Attacher (Small Size)



SAATTE 1250 ASKI  
1250 LOOPS PER HOUR



Temiz Kıvrımsız  
Without Clean Folding Mode

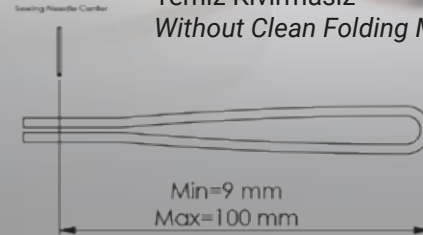

DOKUNMATİK KONTROL  
TOUCH CONTROL



DİJİTAL ÖLÇÜ AYARI  
DIGITAL MEASUREMENT



MAKSİMUM DEVİR  
MAXIMUM SPEED

EFATECH  
SEWING AUTOMATION SYSTEMS



Ek Yeri Algılama Sistemi  
Joint Detection System



Soğuk Kesim.  
Cold Cutting.

### Teknik Özellikler Technical Specifications

Options	SMALL SIZE RIBBON LOOP ATTACHER
SEWING HEAD	40X30 MM BARTACKING MACHINE, AUTOMATIC SEWING
PRODUCTION CAPACITY	1250 PIECE/HOUR
MAX SEWING SPEED	3500 rpm
PNEUMATIC GROUP	SMC
AUTOMATION GROUP	MITSUBISHI
NOISE	MACHINE NOISE WHEN MACHINE OPERATED 3500 RPM Lpa < 84dB
RIBBON CUTTING UNITE	COLD CUTTING
VOLTAGE	220 V
POWER	1 kW / 10 A
AIR PRESSURE	6-7 BAR
NET WEIGHT	165 KG
GROSS WEIGHT	230 KG

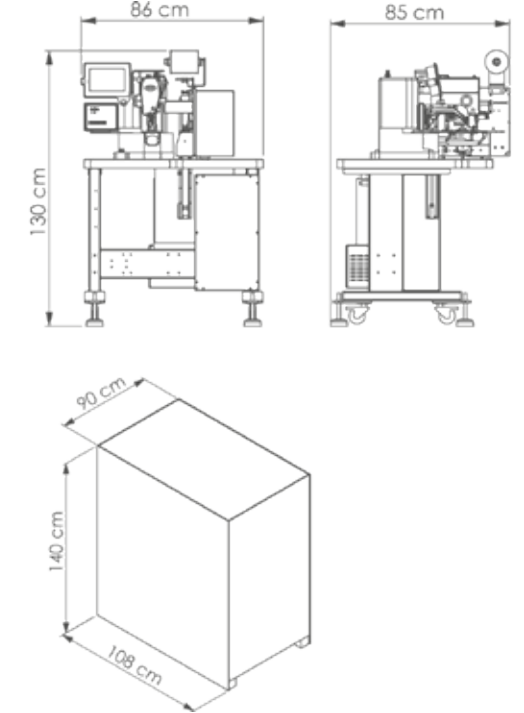



# ASKILIK Otomati

Ultrasonik Saten Askılık Otomati (Tulum Tipi)

## PD-X10RSC

### ULTRASONIC CUTTING

## LOOP Attacher

Ultrasonik Ribbon Loop Attacher (Reverse Mode)



SAATTE 1250 ASKI  
1250 LOOPS PER HOUR



Ultrasonik Kesim  
Ultrasonic cutting



Ek Yeri Algılama Sistemi  
Joint Detection System

#### Teknik Özellikler Technical Specifications

Options	STRAIGHT RIBBON LOOP ATTACHER (REVERSE MODE)
SEWING HEAD	40X30 MM BARTACKING MACHINE, AUTOMATIC SEWING
PRODUCTION CAPACITY	1250 PIECE/HOUR
MAX SEWING SPEED	3500 rpm
PNEUMATIC GROUP	SMC
AUTOMATION GROUP	MITSUBISHI
NOISE	MACHINE NOISE WHEN MACHINE OPERATED 3500 RPM Lpa < 84dB
RIBBON CUTTING UNITE	ULTRASONIC CUTTING
VOLTAGE	220 V
POWER	2 kW / 10 A
AIR PRESSURE	6-7 BAR
NET WEIGHT	190 KG
GROSS WEIGHT	260 KG

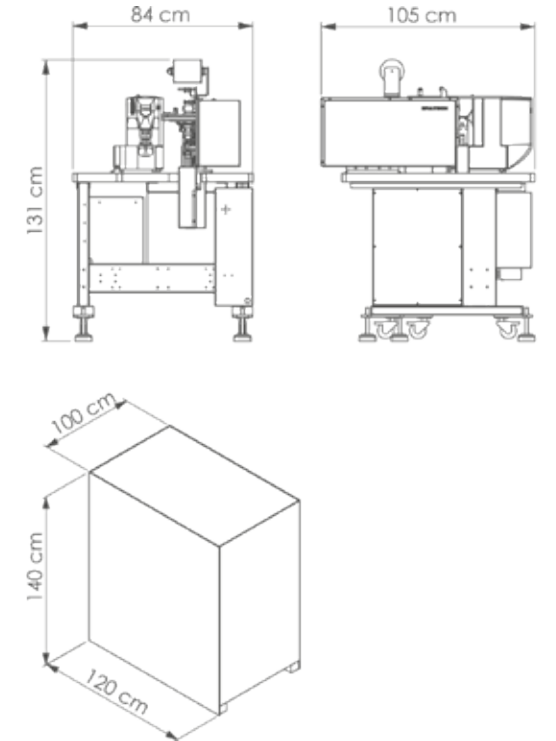

Temiz Kıvrmasız  
Without Clean Folding Mode

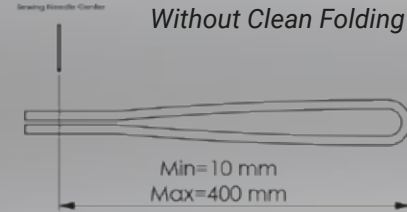

DOKUNMATİK KONTROL  
TOUCH CONTROL



ULTRASONİK  
ULTRASONIC



DİJİTAL ÖLÇÜ AYARI  
DIGITAL MEASUREMENT



MAKSİMUM DEVİR  
MAXIMUM SPEED



# PANTOLON ÇEVİRME Makinası

## PC-500

### TROUSERS TURNING MACHINE



**PC-500B**  
Çanta ve Yastık Kılıfı Çevirme  
Bag and pillowcase Turning

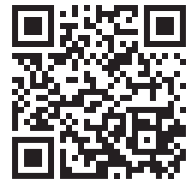

Kolay temizlenebilen bağımsız filtre.  
Easily cleanable separate special filter.



Kullanıcıya göre ayarlanabilen ergonomik tasarım.  
Adjustable to user ergonomic design

#### Teknik Özellikler Technical Specifications

VOLTAGE	380 V
POWER	3 kW / 16 A
PRODUCTION CAPACITY	350 PIECES/HOUR
NOISE	MACHINE NOISE WHEN MACHINE OPERATED 3500 RPM Lpa < 84dB
AIR PRESSURE	6-7 BAR
NET WEIGHT	300 KG
GROSS WEIGHT	450 KG



Ayarlanabilir vakum şiddeti, Açık unutulduğunda otomatik kapanma, Motor soğutma özelliği.

Adjustable vacuum intensity, System shuts off when the machine left on, Motor cooling feature.

#### Teknik Özellikler Technical Specifications

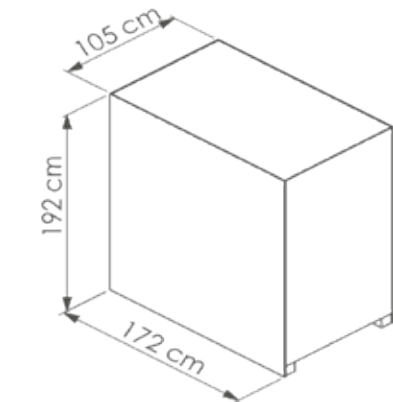
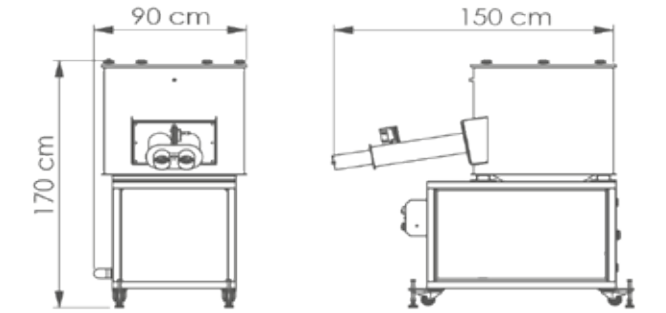





Her marka ve model makinarya takılabilir, Minimum alanda çalışır, İş uzunluğuna göre kolayca ayarlanabilir

Pluggable to all brand and model machines, Minimum work area, Easily adjustable according to work length



İşin akışını kolaylaştıran demonte üst tabla, Paslanmaz krom gövde yapısı

Disassembled upper table which makes the workflow easier, Chromium stainless body structure

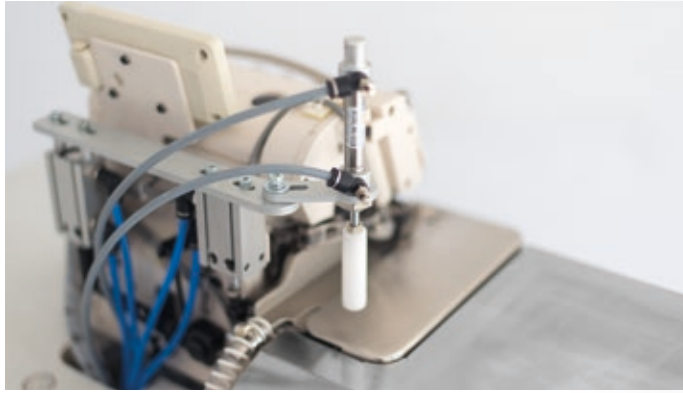

Yaptığınız işi sayabilen sayaç sistemi, Maksimum hızda çalışmaya uygun sistem, İhtiyacınız olmadığında tek tuşla devre dışı bırakılabilir

Counter system counts the work-pieces, Suitable system to work in maximum speed, Inactivate with one button if not needed

#### Teknik Özellikler Technical Specifications

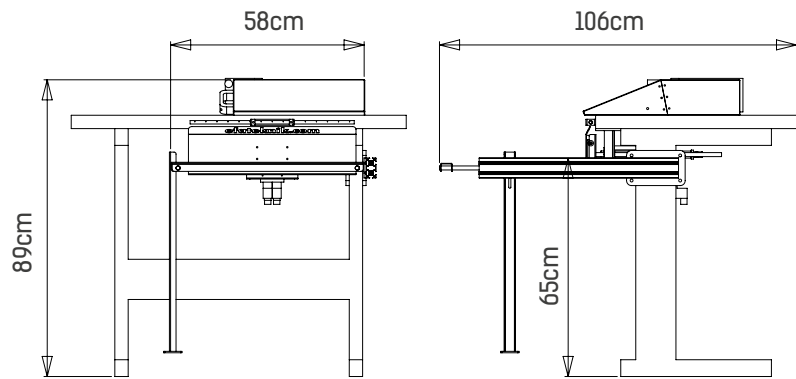

Hava Basıncı Air Pressure	6-7 Bar
Net Ağırlık Net Weight	30kg

## OTOMATİK İSTİFLEME HX-6800T AUTOMATIC STACKING





# ŞERİTLİ DÜĞME OTOMATI

## DK-X30

### STRIPED BUTTON AUTOMAT



5 saniyede düğme dikişi  
Button insert in 5 seconds



Maksimum Devirde İş Dikebilme, Ayarlanabilir İplik Tokatlama Sistemi, Standart Ölçülerde Şerit

Sewing on Maximum speed, Adjustable Thread Pull System, Standart sized straps

#### Teknik Özellikler Technical Specifications

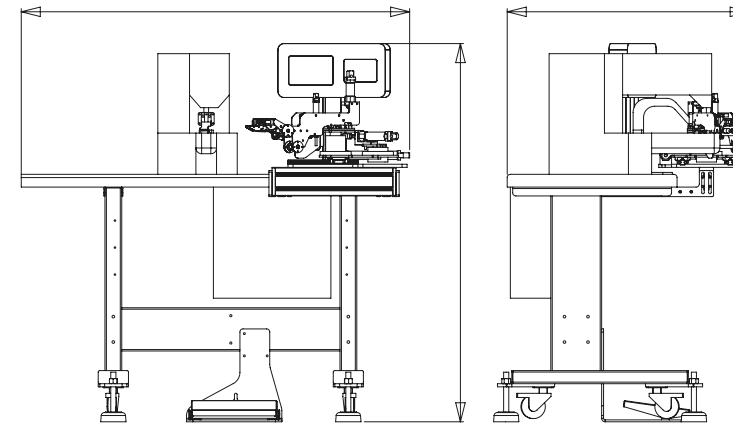

Gerilim Voltage	220V
Güç Power	1KW
Hava Basıncı Air Pressure	6-7 Bar
Net Ağırlık Net Weight	140kg
Bürüt Ağırlık Gross Weight	220kg





# TRACETECH

Tekstil Üretim İzleme ve Raporlama Sistemi  
Textile Production Monitoring and Reporting System

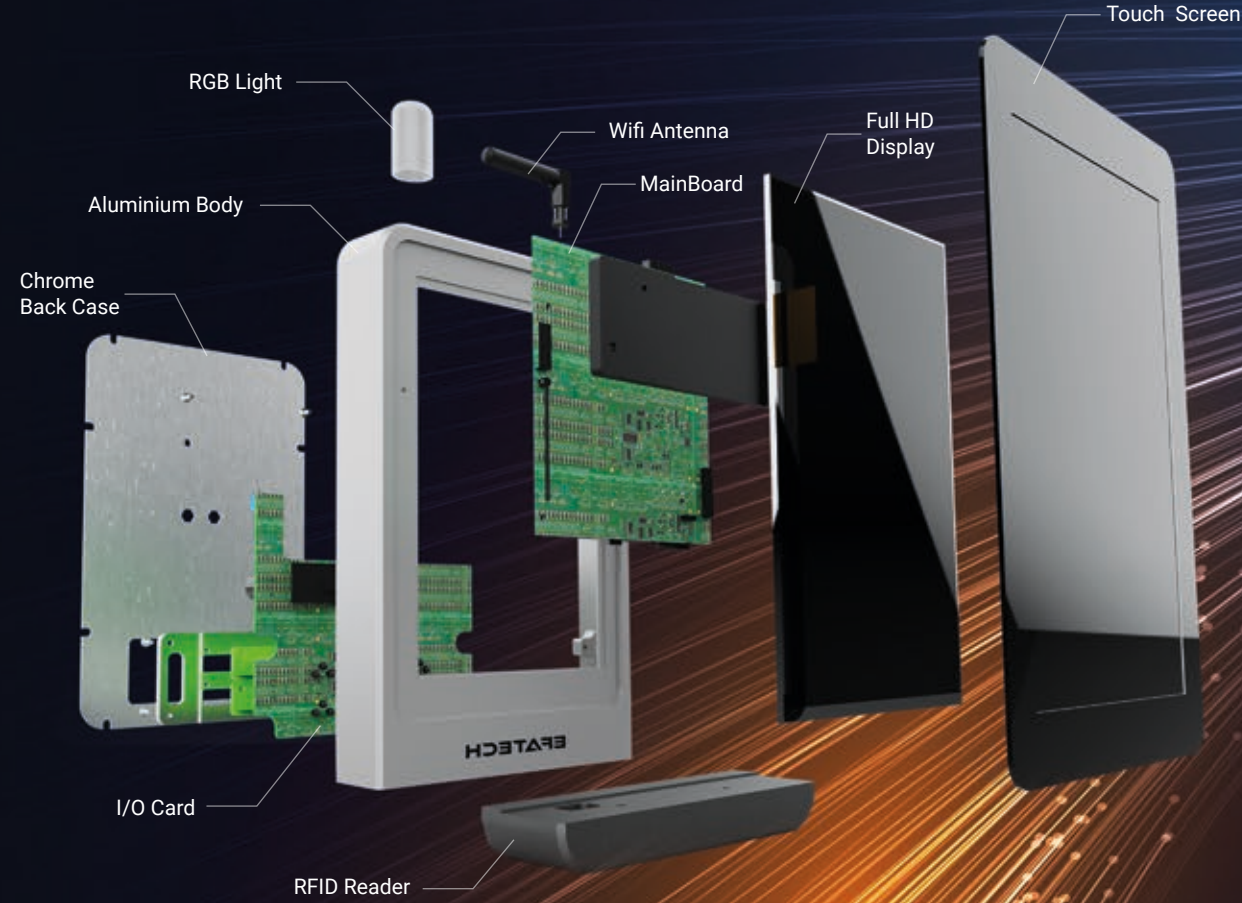

**SEW  
MORE**  
WITH REALTIME  
PRODUCTION  
MONITORING



**TraceTouch**

7" Industrial Tablet  
Data Collecting Device for Textile Production

**Tekstile özel üretildi.**

*Special Design for Sewing Machines*  
**Compact & Durable**



# TRACETECH

Tekstil Üretim İzleme ve Raporlama Sistemi  
Textile Production Monitoring and Reporting System



Dikim Operasyonları  
Sewing Operations



Anlık Bant Bilgi Ekranları  
Production Line Info Displays

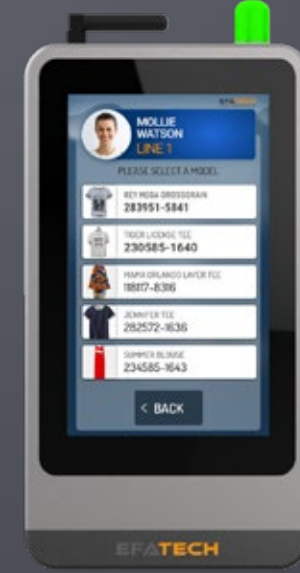

Kalite Kontrol İstasyonları  
Quality Control Stations



Yönetim ve Raporlama Yazılımı  
Management and Reporting Software

- ✓ Çalışanların bireysel verimlilikleri ve üretim süreçlerini kolayca raporlayın.
- ✓ Üretimdeki operasyonların anlık durumunu bilgisayarınızın ekranından takip edin.
- ✓ Performans bilgilerini anlık olarak operatörlere bildirin.
- ✓ Fabrika dışında olsanız bile üretim bilgilerini inceleyin.

- ✓ Easily report individual productivity and production processes of employees.
- ✓ Follow the instant status of operations in production on your computer screen.
- ✓ Report the performance information instant to the operators.
- ✓ Review production information even when you're out of the factory.

Ayrıntılı bilgi için  
for more information





**EFATECH**  
SEWING AUTOMATION SYSTEMS

T: +90 232 431 1221 F: +90 232 431 1223

5747/2 Sokak No:25 6008 Ada MTK Sitesi  
Çamdibi / İZMİR - TURKEY

[www.efatech.com.tr](http://www.efatech.com.tr) [info@efatech.com.tr](mailto:info@efatech.com.tr)